

# INSTRUKTIONSBOK TSV10

Instruktion för svarv  
TSV-8, TSV-10, TMV-10



### UPPSTÄLLNING

Montera maskinen på stadigt underlag, betonggolv el. dyl. Tillse även att maskinen blir rätt uppställd. Om maskinen ej står stadigt, placera små järnkilar under hörnen invid fundamentskruvarna, och kila upp stativen så maskinen står stadigt. Drag därefter åt fundamentbultarna.

### INKOPPLING

Vid inkoppling anslutes nätet på kopplingsplinten som finns monterad i skyddskåpan ( 174 ) bakom frontplattan ( Y-20 ). Tillse att motor och motorskydd är för rätt spänning.

### SMÖRJNING

Använd olja för smörjning av rullager och lagringar. Lämplig olja är MOBIL VACTRA OIL HEAVY MEDIUM eller likvärdig.

### ANSÄTTNING AV SPEL I AXIALLAGREN

Ansättning av spel i axiell riktning på spindeln sker genom att låsmuttern ( X-476 ) ansättes så hårt att spelfrihet erhålles, varefter muttern låses med den innanför placerade låsbrickan ( X-477 ). Maskinen är vid leverans justerad med lämpligt axialspelet på spindeln.

### BYTE AV KILREMMAR

Drivningen sker medelst kilremmar från en i skåpfoten ( TS-170 ) inbyggd helkapslad tvåhastighetsmotor ( X-410 ), över en variator ( X-485 ). Vid byte av kilremmar ( X-483, X-484 ) får man lossa motorhyllan ( TS-227 ) och variatorn ( X-485 ), därefter kan remmarna tagas bort. När nya remmar monterats, tillse att sträckningen blir ungefär lika för båda repen.

### SÄKERHETSANORDNING

Vid användning av chuck, planskiva eller medbringarfläns finnes en enkel säkerhetsanordning för att t.ex. chucken vid häftig inbromsning ej skall gängas av. Det finns fyra gängade hål på spindeln ( TS-176 ) och 3 liknande hål på t.ex. planskivan ( TS-47 ). Man skruvar i 3 skruvar ( X-288 ) i hålen på planskivan och gängar på densamma på spindeln. Därefter syftar man in det hål på spindeln som kommer närmast någon av skruvarna i planskivan, varefter man skruvar i en skruv ( X-288 ) även i spindeln.

**EJCA**

EJCA VERKSTADS AB,  
VÄRNAMO

TSV 10  
Fundamentsritning  
Foundation Drawing Fundamentplan

4.21

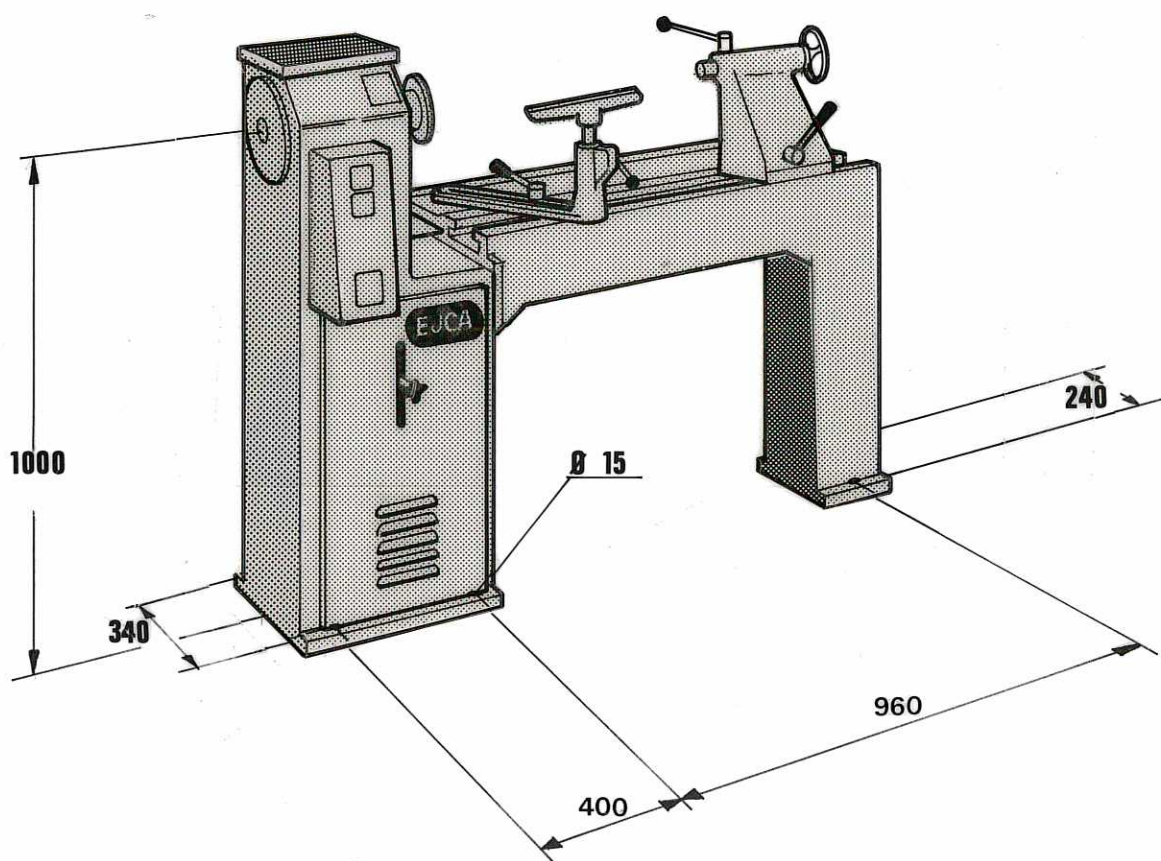

Det. nr. Part No. Teil Nr.	Antal Amount Anzahl	Benämning	Specification	Bezeichnung
<u>TS</u>				
14-2	1	Bricka	Washer	Scheibe
16	1	Svarvanhåll L=120 mm.	Lathe fence L= 120 mm.	Drebankanschlag L= 120 mm.
17	1	Svarvanhåll L=300 mm.	Lathe fence L= 300 mm.	Drebankanschlag L= 300 mm.
19-1	1	Vinkelanhåll	Angle fence	Winkelanschlag
19-2	1	Radieanhåll	Radius fence	Radiusanschlag
24	1	Pinolaxel	Tailstock spindle	Spindel für Reitstock
25	1	Skruv	Screw	Schraube
26	1	Fäste	Holder	Fassung
34	1	Bromsarm	Brake arm	Bremsearm
35	1	Axel	Spindle	Spindel
57	1	Skruv	Screw	Schraube
63	1	Lässskruv	Stop screw	Riegelschraube
64	1	Spak	Lever arm	Hebel
162	1	Fläns	Flange	Flansch
174	1	Apparatlåda	Box for starters	Apparatenkasten
178	1	Motorremskiva	Motor pulley	Motorriemenscheibe
183	1	Exenterskruv	Exentric screw	Exzenterschraube
184	1	Låsmutter	Lock nut	Gegenmutter
210	1	Låsklack	Lock dog	Riegelnocken
211	1	Låsklack	Lock dog	Riegelnocken
215	1	Stativ	Machine body	Gehäuse
217	1	Lucka	Cover	Dekel
218	1	Prisma	Bed	Bett
219	1	Bakdocka	Tailstock	Reitstock
220	1	Exenteraxel	Exentric spindle	Exzenterspindel
221	2	Spak	Lever arm	Hebel
223	1	Axel	Spindle	Spindel
224	1	Axel	Spindle	Spindel
225	1	Ställarm	Adjusting arm	Stellarm
227	1	Motorhylla	Motor plate	Motor platte
232	1	Lock	Cover	Dekel
233	1	Täckplåt	Covering plate	Deckplatte
BA-148	1	Bricka	Washer	Unterlegsscheibe
BA-149	1	Vinkelfäste	Angle holder	Winkelanschlag
RS-188	1	Ratt	Hand wheel	Handrat
RS-223	1	Spak	Lever arm	Hebel
Y-20	1	Frontplatta	Front plate	Frontplatte
X-19	2	Skruv USK6SS 5/16" x 8	Screw USK6SS 5/16" x 8	Gewindestift USK6SS 5/16" x 8
X-21	1	Nutter UL6M 1/4"	Nut UL6M 1/4"	Sechskantmutter UL6M 1/4"
X-33	1	Skruv KFS 1/4" x 19	Screw KFS 1/4" x 19	Linsenkopfschraube KFS 1/4" x 19
X-72	2	Skruv KS 3/16" x 12	Screw KS 3/16" x 12	Halbrundschräube KS 3/16" x 12
X-96	2	Skruv KS 3/8" x 15	Screw KS 3/8" x 15	Halbrundschräube KS 3/8" x 15
X-98	7	Skruv EC6S 1/4" x 20	Screw EC6S 1/4" x 20	Innensechskantschraube
X-147	1	Skruv U6S 1/4" x 45	Screw U6S 1/4" x 45	Sechskantschraube U6S 1/4" x 45
X-153	1	Skruv U6S 5/16" x 25	Screw U6S 5/16" x 25	Sechskantschraube U6S 5/16" x 25
X-162	6	Skruv U6S 3/8" x 25	Screw U6S 3/8" x 25	Sechskantschraube U6S 3/8" x 25
X-165	2	Skruv U6S 3/8" x 51	Screw U6S 3/8" x 51	Sechskantschraube U6S 3/8" x 51
X-178	4	Skruv B6LS W 1/2" x 30	Screw B6LS W 1/2" x 30	Sechskantschraube B6LS W 1/2" x 30
X-182	1	Skruv B6LS W 1/2" x 65	Screw B6LS W 1/2" x 65	Sechskantschraube B6LS W 1/2" x 65
X-273	1	Filtring nr: 7	Felt ring	Filzring
X-304	1	Kullager SKF 6006	Ball bearing SKF 6006	Kugellager SKF 6006
X-341	4	Skruv EC6S 1/4" x 15 L	Screw EC6S 1/4" x 15 L	Innensechskantschraube

Det. nr. Part No. Teil Nr.	Antal Amount Anzahl	Benämning	Specification	Bezeichnung
X-349	1	Handtag HM-2	Handle HM-2	Handgriff HM-2
X-350	1	Skruv KS 1/4" x 10	Screw KS 1/4" x 10	Halbrundschräube KS 1/4" x 10
X-355	10	Skruv ECS 3/16" x 10	Screw ECS 3/16" x 10	Zylinderkopfschräube
X-387	2	Bakelitkula Ø 25 - 5/16"	Bakelite ball Ø 25- 5/16"	Bakelitkugel Ø 25 - 5/16"
X-410	1	Motor	Motor	Motor
X-433	1	Tryckfjäder Ø 13/9 x 40	Pressure spring	Druckfeder
X-452	8	Mutter B6LM 3/8"	Nut B6LM 3/8"	Sechskantmutter B6LM 3/8"
X-464	1	Ställbar låsspak W 1/2"	Hand lever W 1/2"	Handhebel W 1/2"
X-474	1	Skruv KS W 1/2" x 50	Screw KS W 1/2" x 50	Halbrundschräube KS W 1/2" x 50
X-475	2	Bakelithandtag 5012-M8	Bakelite handle 5012-M8	Bakelithandgriff 5012-M8
X-478	1	Maskinratt Din 950 Ø 125	Hand wheel Ø 125	Handrat Ø 125
X-479	1	Impulsbrytare A 176 EG	Starter A 176 EG	Anlasser A 176 EG
X-481	1	Dahlanderomkopplare	Pole change switch	Dahlanderschalter
X-482	1	Kontaktormotorskydd CT-10	Overload Release CT-10	Kontaktormotorschutz CT-10
X-483	1	Kilrep B-31	V-belt B-31	Keilriemen B-31
X-484	1	Kilrep B-50	V-belt B-50	Keilriemen B-50
X-485	1	Variator 55 SF	Variator 55 SF	Variator 55 SF
X-486	2	Mutter B6LM W 1/2"	Nut B6LM W 1/2"	Sechskantmutter B6LM W 1/2"
X-487	1	Bromsband	Brake strip	Bremseband
X-488	2	Mässingskräv FS M4 x 12	Brass screw FS M4 x 12	Messingschräube FS M4 x 12
X-489	1	Reffelpinne RP 8 x 45	Pin RP 8 x 45	Kerbstift RP 8 x 45
X-511	2	Gångjärn 1.½"	Hinge 1.½"	Scharnier 1.½"
X-512	1	Gummiplatta	Rubber plate	Gummiplatte
X-513	1	Skruv ECS 1/4" x 12	Screw ECS 1/4" x 12	Zylinderkopfschräube

**EJCA**

Reservdelista för svarv typ TSV - 8  
 Spare part list for lathe type TSV - 10  
 Ersatzteilliste für Drehbank Type THV - 10

**4,79**

Det. nr. Part No. Teil Nr.	Antal Amount Anzahl	Benämning	Specification	Bezeichnung
TS				
9	1	Spindel	Spindle	Spindel
10	1	Kullagerlock	Locking plate for bearing	Kugellagerdeckel
11	1	Kullagerlock	Locking plate for bearing	Kugellagerdeckel
45	1	Hylsa	Sleeve	Hülse
175	1	Hylsa	Sleeve	Hülse
177	1	Remskiva	Pulley	Riemenscheibe
180	1	Stödtring	Support ring	Stützring
234	1	Hylsa	Sleeve	Hülse
X-163	4	Skruv U6S 3/8" x 38	Screw U6S 3/8" x 38	Sechskantschraube U6S 3/8" x 38
X-274	2	Filtzing	Felt ring	Filtzing
X-288	1	Skruv EC6S 1/4" x 8	Screw EC6S 1/4" x 8	Innensechskantschraube
X-305	2	Rullager SKF 30207	Roller bearings SKF 30207	Rollenlager SKF 30207
X-341	6	Skruv EC6S 1/4" x 15 L	Screw EC6S 1/4" x 15 L	Innensechskantschraube
X-358	2	Skruv U6S 3/8" x 32	Screw U6S 3/8" x 32	Sechskantschraube U6S 3/8" x 32
X-476	1	Låsmutter SKF KM-7	Locking nut	Gegenmutter
X-477	1	Låsbricka SKF MB-7	Locking washer	Sicherungsscheibe



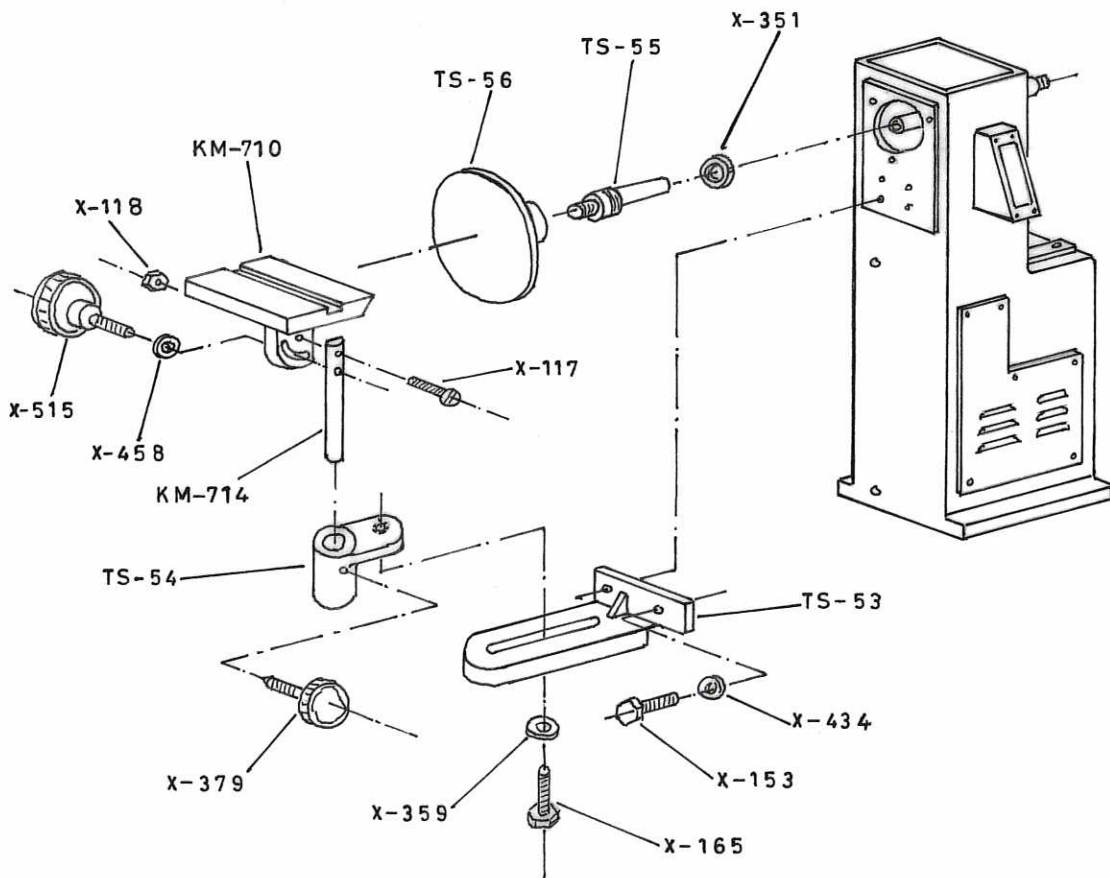
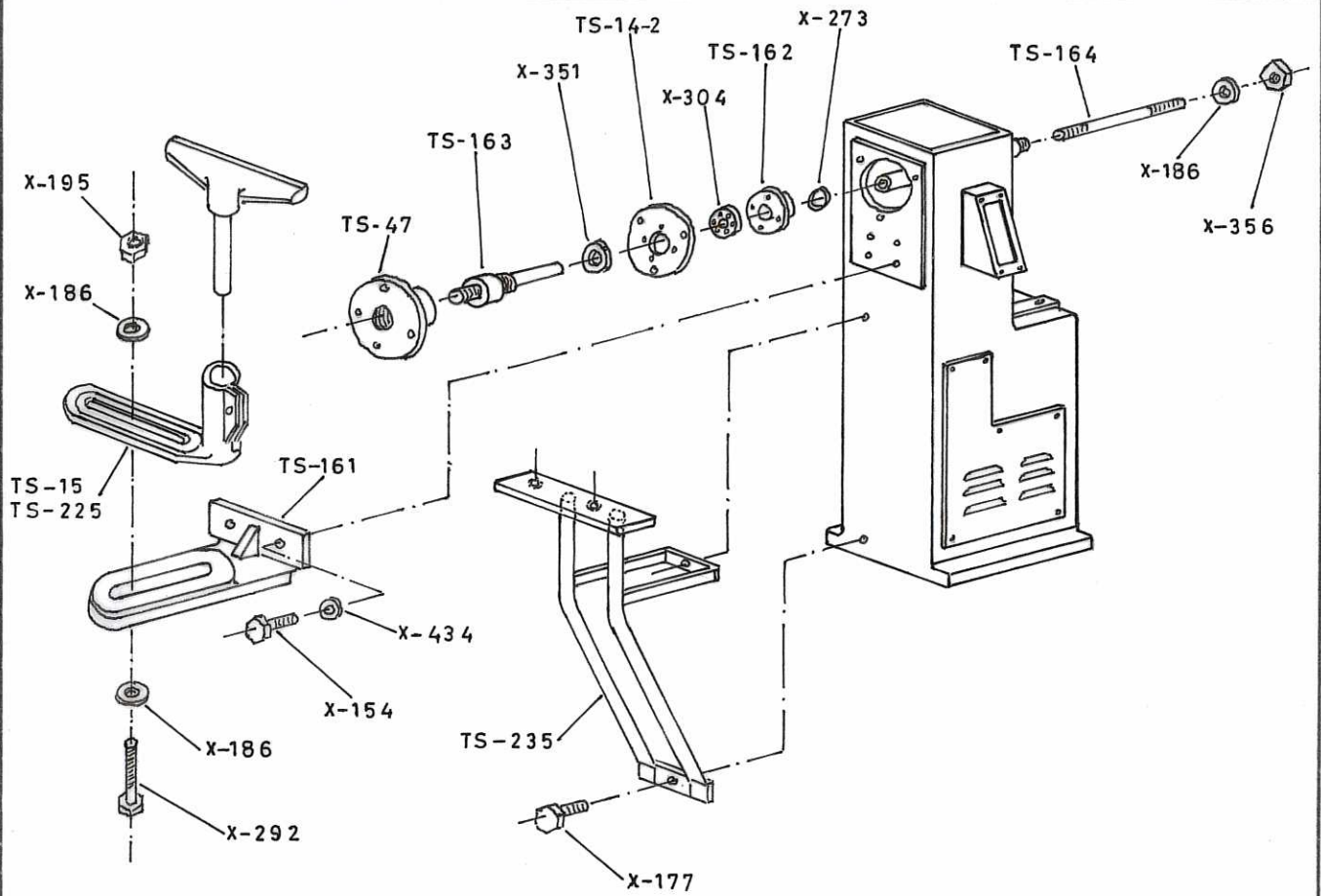



**EJCA**

Fundamentritning för svarv typ

Foundation Drawing for lathe type TSV - 8

Fundamentplan für Drehbank Type

4,23

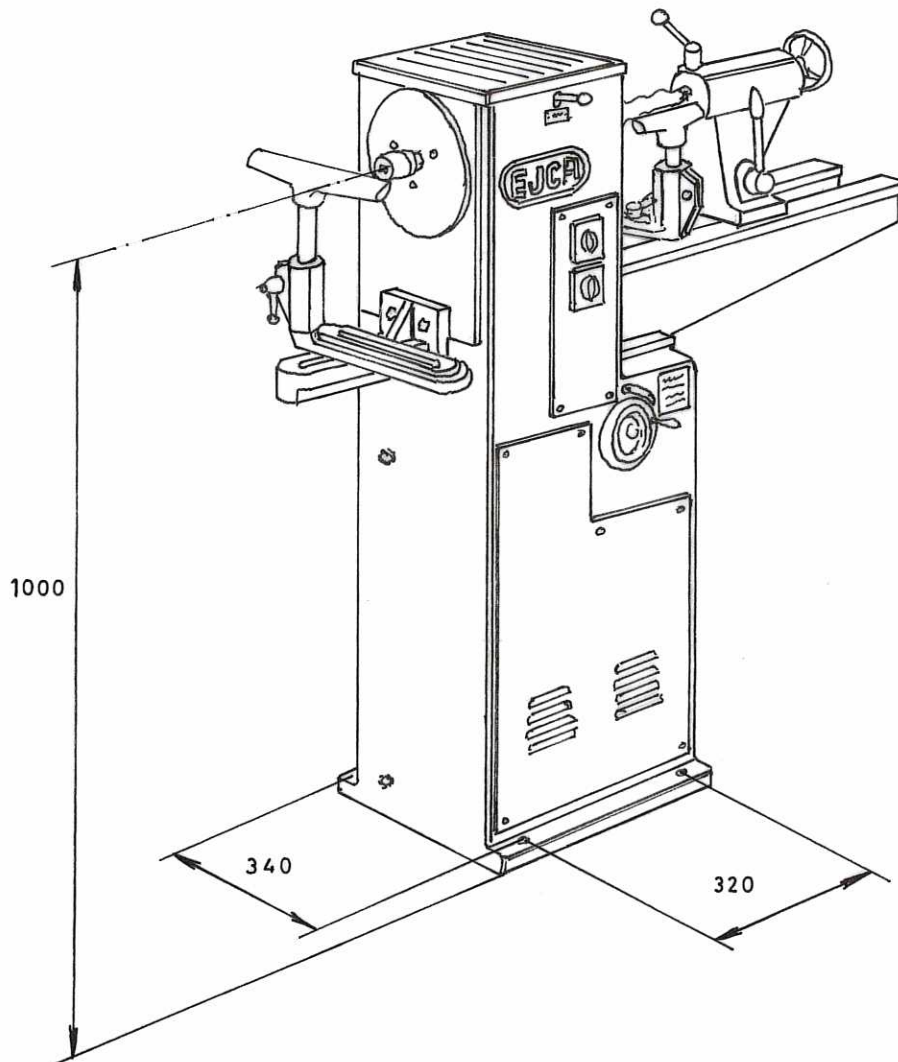

Reservdelista för svarv typ TSV - 8  
 Spare part list for lathe type TS- 10  
 Ersatzteilliste für Drehbank Type TSM- 10

4,82

Det. nr. Part No. Teil Nr.	Antal Amount Anzahl	Benämning	Specification	Bezeichnung
TS-14-2	1	Bricka	Washer	Scheibe
TS-15	1	Ställarm - TS-10	Adjusting arm TS-10	Stellarm TS-10
TS-47	1	Planskiva	Face plate	Planscheibe
TS-161	1	Fästarm	Holder arm	Halterarm
TS-162	1	Fläns	Flange	Flansch
TS-163	1	Spindel	Spindle	Spindel
TS-164	1	Axel	Spindle	Spindel
TS-225	1	Ställarm TSV-8	Adjusting arm TSV-8	Stellarm TSV-8
TS-235	1	Fäste	Holder	Halter
X-154	2	Skruv U6S 5/16" x 38	Screw U6S 5/16" x 38	Sechskantschraube U6S 5/16" x 38
X-177	2	Skruv B6LS W 1/2" x 25	Screw B6LS W 1/2" x 25	Sechskantschraube W 1/2" x 25
X-186	3	Bricka BRB 1/2"	Washer BRB 1/2"	Scheibe BRB 1/2"
X-195	1	Mutter B6M W 1/2"	Nut B6M W 1/2"	Sechskantmutter B6M W 1/2"
X-273	1	Filtring nr: 7	Felt washer	Filzring
X-292	1	Skruv B6LS W 1/2" x 90	Screw B6LS W 1/2" x 90	Sechskantschraube W 1/2" x 90
X-304	1	Kullager SKF 6006	Ball bearing SKF 6006	Kugellager SKF 6006
X-351	1	Låsmutter SKF KM-5	Locking nut SKF KM-5	Gegenmutter SKF KM-5
X-356	1	Mutter M6M M 12	Nut M6M M 12	Sechskantmutter M6M M 12
X-434	2	Bricka BRB 5/16"	Washer BRB 5/16"	Scheibe BRB 5/16"
TS-53	1	Fästarm	Holder arm	Halterarm
TS-54	1	Fäste	Holder	Halter
TS-55	1	Spindel	Spindle	Spindel
TS-56	1	Putsskiva	Polishing disk	Putzscheibe
KM-710	1	Putsbord	Polishing table	Putztisch
KM-714	1	Axel	Spindle	Spindel
X-117	1	Skruv KS 5/16" x 50	Screw KS 5/16" x 50	Halbrundschrave KS 5/16" x 50
X-118	1	Mutter B6LM 5/16"	Nut B6LM 5/16"	Sechskantmutter B6LM 5/16"
X-153	2	Skruv U6S 5/16" x 25	Screw U6S 5/16" x 25	Sechskantschraube U6S 5/16" x 25
X-165	1	Skruv U6S 3/8" x 51	Screw U6S 3/8" x 51	Sechskantschraube U6S 3/8" x 51
X-351	1	Låsmutter SKF KM-5	Locking nut SKF KM-5	Gegenmutter SKF KM-5
X-359	1	Bricka BRB 3/8"	Washer BRB 3/8"	Scheibe BRB 3/8"
X-379	1	Bakelittratt M10 x 30	Bakelite handle M10 x 30	Bakelithandrad M10 x 30
X-434	2	Bricka BRB 5/16"	Washer BRB 5/16"	Scheibe BRB 5/16"
X-458	1	Bricka BRB M 8	Washer BRB M 8	Scheibe BRB M 8
X-515	1	Bakelittratt M 8 x 45	Bakelite handle M8 x 45	Bakelithandrad M8 x 45



Reservdelslista för svarv typ TSV - 10  
 Spare part list for lathe type TMV - 10  
 Ersatzteilliste für Drehbank Type

4,74

Det. nr. Part No. Teil Nr.	Antal Amount Anzahl	Benämning	Specification	Bezeichnung
<u>TS</u>				
15	1	Ställarm	Adjusting arm	Stellarm
16	1	Svarvyanhäll L= 120 mm.	Lathe fence L= 120 mm.	Drehbankanschlag L= 120 mm.
17	1	Svarvyanhäll L= 300 mm.	Lathe fence L= 300 mm.	Drehbankanschlag L= 300 mm.
18	1	Svarvyanhäll L= 600 mm.	Lathe fence L= 600 mm.	Drehbankanschlag L= 600 mm.
19-1	1	Vinkelanhäll	Angle fence	Winkelanschlag
19-2	1	Radieanhäll	Radius fence	Radiusanschlag
23	1	Bakdocka	Tailstock	Reitstock
24	1	Pinolaxel	Tailstock spindle	Spindel für Reitstock
25	1	Skruv	Screw	Schraube
26	1	Fäste	Holder	Fassung
34	1	Bromsarm	Brake arm	Bremsearm
35	1	Axel	Spindle	Spindel
57	1	Skruv	Screw	Schraube
63	1	Lässkruv	Stop screw	Riegelschraube
64	1	Spak	Lever arm	Hebel
170	1	Stativ	Machine body	Gehäuse
171	1	Lucka	Vent	Dekel
172	1	Prisma	Bed	Bett
173	1	Fotstativ	Frame	Gestell
174	1	Apparatlåda	Box for starters	Apparatenkasten
178	1	Motorremskiva	Motor pulley	Motorriemenscheibe
181	1	Exenteraxel	Exentric spindle	Exzentrerspindel
182	2	Spak	Lever arm	Hebel
183	1	Exenterskruv	Excentric screw	Exzentrerschraube
184	1	Låsmutter	Lock nut	Gegenmutter
210	1	Låsklack	Lock dog	Riegelnocken
211	1	Låsklack	Lock dog	Riegelnocken
213	1	Axel	Spindle	Spindel
227	1	Motorhylla	Motor plate	Motor platte
BA-148	1	Bricka	Washer	Unterlegscheibe
BA-149	1	Vinkelfäste	Angle holder	Winkelanschlag
RS-188	1	Ratt	Hand wheel	Handrat
RS-223	1	Spak	Lever arm	Hebel
Y-20	1	Frontplatta	Front plate	Frontplatte
X-19	1	Skruv USK6SS 5/16" x 8	Screw USK6SS 5/16" x 8	Gewindestift USK6SS 5/16" x 8
X-21	1	Mutter UL6M 1/4"	Nut UL6M 1/4"	Sechskantmutter UL6M 1/4"
X-33	1	Skruv KFS 1/4" x 19	Screw KFS 1/4" x 19	Linsenkopfschraube KFS 1/4" x 19
X-72	2	Skruv KS 3/16" x 12	Screw KS 3/16" x 12	Halbrundschräube KS 3/16" x 12
X-96	2	Skruv KS 3/8" x 15	Screw KS 3/8" x 15	Halbrundschräube KS 3/8" x 15
X-147	1	Skruv U6S 1/4" x 45	Screw U6S 1/4" x 45	Sechskantschraube U6S 1/4" x 45
X-153	1	Skruv U6S 5/16" x 25	Screw U6S 5/16" x 25	Sechskantschraube U6S 5/16" x 25
X-162	4	Skruv U6S 3/8" x 25	Screw U6S 3/8" x 25	Sechskantschraube U6S 3/8" x 25
X-163	4	Skruv U6S 3/8" x 38	Screw U6S 3/8" x 38	Sechskantschraube U6S 3/8" x 38
X-165	2	Skruv U6S 3/8" x 51	Screw U6S 3/8" x 51	Sechskantschraube U6S 3/8" x 51
X-170	1	Skruv U6S 5/16" x 70	Screw 5/16" x 70	Sechskantschraube U6S 5/16" x 70
X-179	4	Skruv B6LS W 1/2" x 35	Screw B6LS W 1/2" x 35	Sechskantschraube B6LS W 1/2" x 35
X-182	1	Skruv B6LS W 1/2" x 65	Screw B6LS W 1/2" x 65	Sechskantschraube B6LS W 1/2" x 65
X-237	1	Stift FRP 3 x 25	Pin FRP 3 x 25	Zylinderstift FRP 3 x 25
X-341	8	Skruv EC6S 1/4" x 15 L.	Screw EC6S 1/4" x 15 L.	Innensechskantschraube
X-349	1	Handtag HM-2	Handle HM-2	Handgriff HM-2
X-350	1	Skruv KS 1/4" x 10	Screw KS 1/4" x 10	Halbrundschräube KS 1/4" x 10
X-355	8	Skruv ECS 3/16" x 10	Screw ECS 3/16" x 10	Zylinderkopfschraube



Reservdelista för svarv typ

Spare part list for lathe type

Ersatzteilliste für Drehbank Type

TSV - 10

TMV - 10

4,74

Det. nr. Part No. Teil Nr.	Antal Amount Anzahl	Benämning	Specification	Bezeichnung
<u>IS</u>				
15	1	Ställarm	Adjusting arm	Stellarm
16	1	Svarvanhåll L= 120 mm.	Lathe fence L= 120 mm.	Drehbankanschlag L= 120 mm.
17	1	Svarvanhåll L= 300 mm.	Lathe fence L= 300 mm.	Drehbankanschlag L= 300 mm.
18	1	Svarvanhåll L= 600 mm.	Lathe fence L= 600 mm.	Drehbankanschlag L= 600 mm.
19-1	1	Vinkelanhåll	Angle fence	Winkelanschlag
19-2	1	Radieanhåll	Radius fence	Radiusanschlag
23	1	Bakdocka	Tailstock	Reitstock
24	1	Pinolaxel	Tailstock spindle	Spindel für Reitstock
25	1	Skruv	Screw	Schraube
26	1	Fäste	Holder	Fassung
34	1	Bromsarm	Brake arm	Bremsearm
35	1	Axel	Spindle	Spindel
57	1	Skruv	Screw	Schraube
63	1	Lässkruv	Stop screw	Riegelschraube
64	1	Spak	Lever arm	Hebel
170	1	Stativ	Machine body	Gehäuse
171	1	Lucka	Vent	Dakel
172	1	Prisma	Bed	Bett
173	1	Fotstativ	Frame	Gestell
174	1	Apparatlåda	Box for starters	Apparatenkasten
178	1	Motorremskiva	Motor pulley	Motorriemenscheibe
181	1	Exenteraxel	Exentric spindle	Exzentrerspindel
182	2	Spak	Lever arm	Hebel
183	1	Exenterskruv	Excentric screw	Exzentrerschraube
184	1	Låsmutter	Lock nut	Gegenmutter
210	1	Låsklack	Lock dog	Riegelnocken
211	1	Låsklack	Lock dog	Riegelnocken
213	1	Axel	Spindle	Spindel
227	1	Motorhylla	Motor plate	Motor platte
BA-148	1	Bricka	Washer	Unterlegscheibe
BA-149	1	Vinkelfäste	Angle holder	Winkelanschlag
RS-188	1	Ratt	Hand wheel	Handrat
RS-223	1	Spak	Lever arm	Hebel
Y-20	1	Frontplatta	Front plate	Frontplatte
X-19	1	Skruv USK6SS 5/16" x 8	Screw USK6SS 5/16" x 8	Gewindestift USK6SS 5/16" x 8
X-21	1	Mutter UL6M 1/4"	Nut UL6M 1/4"	Sechskantmutter UL6M 1/4"
X-33	1	Skruv KFS 1/4" x 19	Screw KFS 1/4" x 19	Linsenkopfschraube KFS 1/4" x 19
X-72	2	Skruv KS 3/16" x 12	Screw KS 3/16" x 12	Halbrundschrave KS 3/16" x 12
X-96	2	Skruv KS 3/8" x 15	Screw KS 3/8" x 15	Halbrundschrave KS 3/8" x 15
X-147	1	Skruv U6S 1/4" x 45	Screw U6S 1/4" x 45	Sechskantschraube U6S 1/4" x 45
X-153	1	Skruv U6S 5/16" x 25	Screw U6S 5/16" x 25	Sechskantschraube U6S 5/16" x 25
X-162	4	Skruv U6S 3/8" x 25	Screw U6S 3/8" x 25	Sechskantschraube U6S 3/8" x 25
X-163	4	Skruv U6S 3/8" x 38	Screw U6S 3/8" x 38	Sechskantschraube U6S 3/8" x 38
X-165	2	Skruv U6S 3/8" x 51	Screw U6S 3/8" x 51	Sechskantschraube U6S 3/8" x 51
X-170	1	Skruv U6S 5/16" x 70	Screw 5/16" x 70	Sechskantschraube U6S 5/16" x 70
X-179	4	Skruv B6LS W 1/2" x 35	Screw B6LS W 1/2" x 35	Sechskantschraube B6LS W 1/2" x 35
X-182	1	Skruv B6LS W 1/2" x 65	Screw B6LS W 1/2" x 65	Sechskantschraube B6LS W 1/2" x 65
X-237	1	Stift FRP 3 x 25	Pin FRP 3 x 25	Zylinderstift FRP 3 x 25
X-341	8	Skruv EC6S 1/4" x 15 L.	Screw EC6S 1/4" x 15 L.	Innensechskantschraube
X-349	1	Handtag HM-2	Handle HM-2	Handgriff HM-2
X-350	1	Skruv KS 1/4" x 10	Screw KS 1/4" x 10	Halbrundschrave KS 1/4" x 10
X-355	8	Skruv ECS 3/16" x 10	Screw ECS 3/16" x 10	Zylinderkopfschraube



Reservdelslista för svarv typ  
Spare part list for lathe type TSV - 10  
Ersatzteilliste für Drehbank Type THV - 10

4,74

Det. nr.	Antal			
Part No.	Amount			
Teil Nr.	Anzahl	Benämning	Specification	Bezeichnung
X-387	2	Bakelitkula $\emptyset$ 25-5/16"	Bakelite ball $\emptyset$ 25-5/16"	Bakelitkugel $\emptyset$ 25-5/16"
X-410	1	Motor	Motor	Motor
X-433	1	Tryckfjäder $\emptyset$ 13/9 x 40	Pressure spring	Drukfeder
X-452	8	Mutter B6LM 3/8"	Nut B6LM 3/8"	Sechskantmutter B6LM 3/8"
X-464	1	Ställbar låsspak W 1/2"	Hand lever W 1/2"	Handhebel W 1/2"
X-474	1	Skruv KS W 1/2" x 50	Screw KS W 1/2" x 50	Halbrundschräube KS W 1/2" x 50
X-475	2	Bakelithandtag 5012-M 8	Bakelite handle 5012-M 8	Bakelithandgriff 5012-M 8
X-478	1	Maskinratt DIN 950 $\emptyset$ 125	Hand wheel DIN 950 $\emptyset$ 125	Handrat DIN 950 $\emptyset$ 125/12
X-479	1	Impulsbrytare C14 A176 EG	Starter C14 A176 EG	Anlasser
X-481	1	Dahlanderomkopplare	Pole change switch	Dahlanderschalter
X-482	1	Kontaktormotorskydd CT-10	Overload Release CT-10	Kontaktormotorschutz CT-10
X-483	1	Kilrep B-31	V-Belt B-31	Keilriemen B-31
X-484	1	Kilrep B-50	V-Belt B-50	Keilriemen B-50
X-485	1	Variator 55 SF	Variator 55 SF	Variator 55 SF
X-486	3	Mutter B6LM W 1/2"	Nut B6LM W 1/2"	Sechskantmutter B6LM W 1/2"
X-487	1	Bromsband	Brake strip	Bremseband
X-488	2	Mässingskruv FS M4 x 12	Brass screw FS M4 x 12	Messingschraube FS M4 x 12
X-489	1	Reffelpinne RP 8 x 45	Pin RP 8 x 45	Kerbstift RP 8 x 45



Reservdelistsa för svarv typ  
Spare part list for lathe type  
Ersatzteilliste für Drehbank Type

TSV - 8  
TSV - 10  
THV - 10



4,80

